

COMPETITION RULES

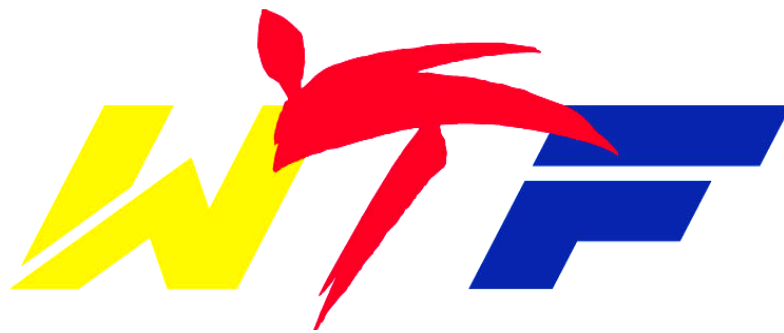

World Taekwondo Federation

CONTENTS

(Article 1. Purpose)	3
(Article 2. Application)	3
(Article 3. Competition Area)	3
(Article 4. Contestant)	6
(Article 5. Weight Division)	7
(Article 6. Classification and Methods of Competition)	8
(Article 7. Duration of Contest)	9
(Article 8. Drawing of Lots)	10
(Article 9. Weigh-in)	10
(Article 10. Procedure of the Contest)	10
(Article 11. Permitted Techniques and Areas)	12
(Article 12. Valid Points)	12
(Article 13. Scoring and Publication)	13
(Article 14. Prohibited acts and Penalties)	13
(Article 15. Sudden Death and Decision of Superiority)	15
(Article 16. Decisions)	15
(Article 17. Knock Down)	16
(Article 18. Procedure in the event of a Knock Down)	16
(Article 19. Procedures for suspending the match)	17
(Article 20. Refereeing Officials)	18
(Article 21. Recorder)	19
(Article 22. Assignment of Refereeing Officials)	19
(Article 23. Other matters not specified in the Rules)	19
(Article 24. Arbitration and Sanction)	20

COMPETITION RULES

Article 1. Purpose

The purpose of the Competition Rules is to manage fairly and smoothly all matters pertaining to competitions of all levels to be promoted and / or organized by the WTF, Regional Unions and member National Associations, ensuring the application of standardized rules.

Article 2. Application

The Competition Rules shall apply to all the competitions to be promoted and / or organized by the WTF, each Regional Union and member National Association. However, any member National Association wishing to modify some any part of the Competition Rules must first gain the approval of the WTF.

Article 3. Competition Area

The Competition Area shall measure 10m x 10m using the metric system. The Competition Area shall have a flat surface without any obstructing projections, and be covered with an elastic mat.

The Competition Area may also be installed on a platform 0.5m - 0.6m high from the base, if necessary, and the outer part of the Boundary Line shall be inclined with a gradient of less than 30 degrees, for the safety of the contestants.

1. Demarcation of the Competition Area

- 1) The 10m x 10m area shall be called the Competition Area, and the marginal line of the Competition Area shall be called the Boundary Line. The front Boundary Line adjacent to the Recorder's Desk and the Commission Doctor's Desk shall be deemed Boundary Line #1. Clockwise from Boundary Line #1, the other lines shall be called Boundary Lines #2, #3, and #4.

2. Indication of Positions

- 1) Position of the Referee

The position of the Referee shall be marked at a point 1.5m back from the center

point of the Contest Area to the 3rd Boundary Line and designated as the Referee's Mark.

2) Position of the Judges

The position of the 1st Judge shall be marked at a point 0.5m from the corner of boundary line #1 and boundary line #2. The position of the 2nd Judge shall be marked at a point 0.5m from the corner of boundary line #2 and boundary line #3. The position of the 3rd Judge shall be marked at a point 0.5m from the corner of boundary line #3 and boundary line #4. The position of the 4th Judge shall be marked at a point 0.5m from the corner of boundary line #4 and boundary line #1.

3) Position of the Recorder

The position of the Recorder shall be marked at a point 2m back from boundary line #1 facing the Competition Area 2m adjacent to the corner of boundary line #1 and boundary line #2.

4) Position of the Commission Doctor

The position of the Commission Doctor shall be marked at a point more than 3m to the right side from the Boundary Line.

5) Positions of the Contestants

The position of the Contestants shall be marked at two opposing points, 1m from the center point of the Competition Area, 5m from Boundary Line #1 (red Contestant toward Boundary Line #2 and blue Contestant toward #4).

6) Position of the Coaches

The position of the Coaches shall be marked at a point 1m away from the center point of the Boundary Line of each contestant's side.

7) Position of the Inspection Desk

The position of the Inspection Desk shall be near the entrance of the Competition Area for inspection of the contestants' protective equipment.

Diagram 1. Field of Taekwondo Play

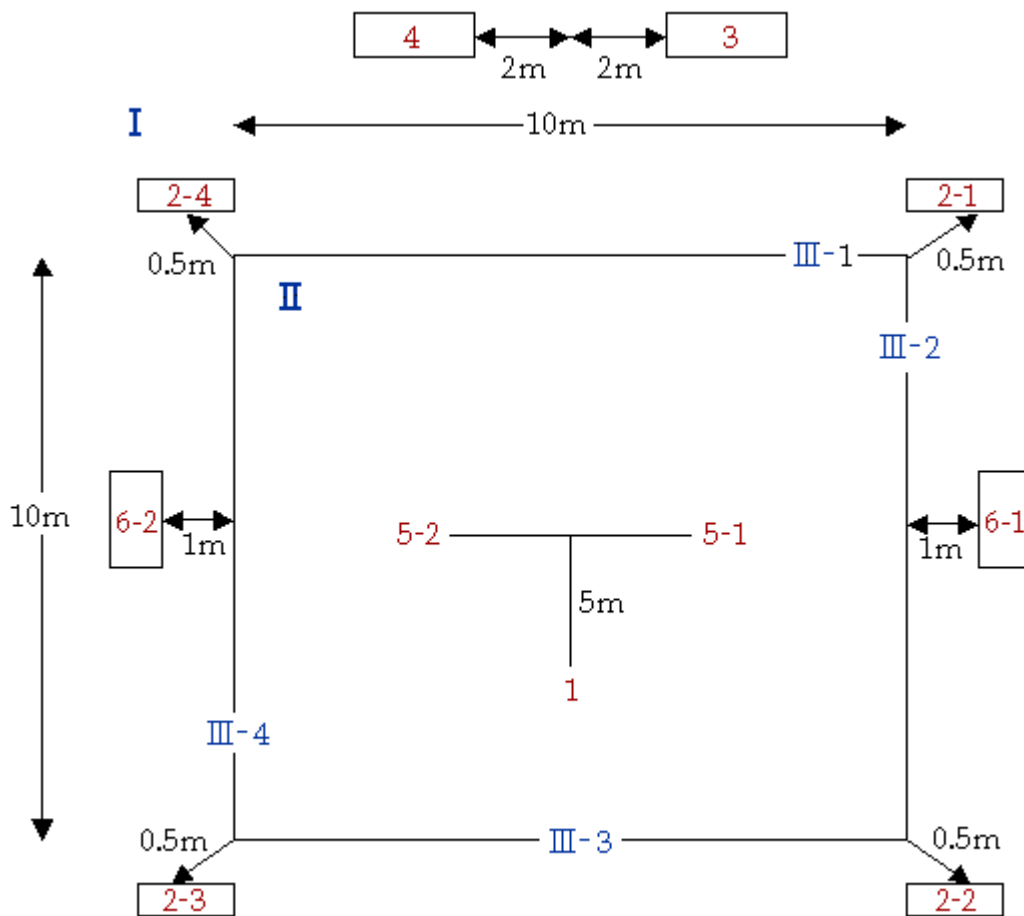

I . Field of Taekwondo Play

II . Competition Area

III. Boundary

III-1. 1st Boundary Line

III-2. 2nd Boundary Line

III-3. 3rd Boundary Line

III-4. 4th Boundary Line

1. Referee's Mark

2. Judge's Mark

3. Recorder's Mark

4. Commission Doctor's mark

5-1. Blue Contestant's mark

5-2. Red Contestant's mark

6-1. Blue Coach's mark

6-2. Red Coach's mark

Diagram 2. Competition Platform

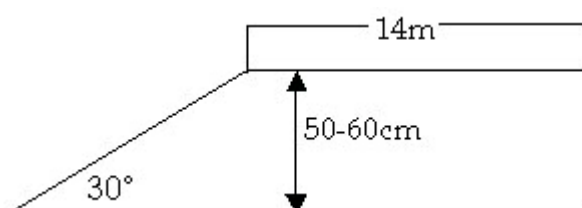

Article 4. Contestant

1. Qualification of Contestant

- 1) Holder of the nationality of the participating team
- 2) One recommended by the national Taekwondo Association
- 3) Holder of Taekwondo Dan certificate issued by the Kukkiwon / WTF, and in case of the World Junior Taekwondo Championships, holder of Kukkiwon Poom / Dan certificate aged 14 through 17 years old based on the year when the Championships are held.

2. Contestant Uniform and Protective Equipment

- 1) The contestant shall wear the trunk protector, head protector, groin guard, forearm guards, shin guards, gloves and a mouthpiece before entering the contest area.
- 2) The groin guard, forearm guards and shin guards shall be worn beneath the Taekwondo uniform. The contestant shall bring this WTF-approved protective equipment, as well as gloves and the mouthpiece, for his/her personal use. Wearing any item on the head other than the head protector shall not be permitted.

3. Medical Control

- 1) At the Taekwondo events promoted or sanctioned by the WTF, any use or administration of drugs or chemical substances described in the WTF Anti-doping by-laws is prohibited. However, the IOC Anti-doping by-laws shall be applied to the Taekwondo competition of Olympic Games and other multi-sports Games.
- 2) The WTF may carry out any medical testing deemed necessary to ascertain if a contestant has committed a breach of this rule, and any winner who refuses to undergo this testing or who proves to have committed such a breach shall be removed from the final standings, and the record shall be transferred to the contestant next in line in the competition standings.
- 3) The Organizing Committee shall be liable for arrangements to carry out medical testing.

- 4) The details of the WTF Anti-Doping Regulation shall be enacted as part of the by-laws.

Article 5. Weight Division

1. Weights are divided into male and female divisions.

2. Weight divisions are basically divided as follows;

<u>Weight category</u>	<u>Male division</u>	<u>Female division</u>
Fin	Not exceeding 54kg	Not exceeding 47 kg
Fly	Over 54 kg & Not exceeding 58 kg	Over 47 kg & Not exceeding 51 kg
Bantam	Over 58 kg & Not exceeding 62 kg	Over 51 kg & Not exceeding 55 kg
Feather	Over 62 kg & Not exceeding 67 kg	Over 55 kg & Not exceeding 59 kg
Light	Over 67 kg & Not exceeding 72 kg	Over 59 kg & Not exceeding 63 kg
Welter	Over 72 kg & Not exceeding 78 kg	Over 63 kg & Not exceeding 67 kg
Middle	Over 78 kg & Not exceeding 84 kg	Over 67 kg & Not exceeding 72 kg
Heavy	Over 84 kg	Over 72 kg

3. Weight divisions for the Olympic Games are divided as follows;

<u>Male division</u>	<u>Female division</u>
Not exceeding 58kg	Not exceeding 49kg
Over 58kg & not exceeding 68kg	Over 49kg & not exceeding 57kg
Over 68kg & not exceeding 80kg	Over 57kg & not exceeding 67kg
Over 80kg	Over 67kg

4. Weight divisions for the World Junior Championships are divided as follows.

<u>Weight category</u>	<u>Male division</u>	<u>Female division</u>
Fin	Not exceeding 45kg	Not exceeding 42 kg
Fly	Over 45 kg & Not exceeding 48 kg	Over 42 kg & Not exceeding 44 kg
Bantam	Over 48 kg & Not exceeding 51 kg	Over 44 kg & Not exceeding 46 kg
Feather	Over 51 kg & Not exceeding 55 kg	Over 46 kg & Not exceeding 49 kg
Light	Over 55 kg & Not exceeding 59 kg	Over 49 kg & Not exceeding 52 kg
Welter	Over 59 kg & Not exceeding 63 kg	Over 52 kg & Not exceeding 55 kg
Light Middle	Over 63 kg & Not exceeding 68 kg	Over 55 kg & Not exceeding 59 kg
Middle	Over 68 kg & Not exceeding 73 kg	Over 59 kg & Not exceeding 63 kg
Light Heavy	Over 73 kg & Not exceeding 78 kg	Over 63 kg & Not exceeding 68 kg
Heavy	Over 78 kg	Over 68 kg

Article 6. Classification and Methods of Competition

1. Competitions are divided as follows.

- 1) Individual competition shall normally be between contestants in the same weight class. When necessary, adjoining weight class may be combined to create a single classification. No contestant is allowed to participate in more than one (1) weight category in one event.
- 2) Team Competition: Systems of Competition
 - (1) Five (5) contestants by weight classification with the following category

Male division

Not exceeding 54kg
 Over 54kg & not exceeding 63kg
 Over 63kg & not exceeding 72kg
 Over 72kg & not exceeding 82kg
 Over 82kg

Female division

Not exceeding 47kg
 Over 47kg & not exceeding 54kg
 Over 54kg & not exceeding 61kg
 Over 61kg & not exceeding 68kg
 Over 68kg

- (2) Eight (8) contestants by weight classification
- (3) Four (4) contestants by weight classification (Consolidation of the eight weight classifications into four weight categories by combining two adjoining weight classes)

2. Systems of competition are divided as follows.

- 1) Single elimination tournament system
- 2) Round robin system

3. Taekwondo competition of the Olympic Games shall be conducted in individual competition system between contestants.

4. All International-level competitions recognized by the WTF shall be formed with participation of at least 4 countries with no less than 4 contestants in each weight class, and any weight class with less than 4 contestants cannot be recognized in the official results.

*Point system

Team ranking shall be decided by the total points based on the following guidelines.

- Basic one (1) point per each contestant who entered the competition area after passing the official weigh-in
- One (1) point per each win (win by a bye included)
- Additional seven (7) points per one gold medal
- Additional three (3) points per one silver medal
- Additional one (1) point per one bronze medal

In case more than two (2) teams are in tie score, the rank shall be decided by 1) number of gold, silver and bronze medals won by the team in order, 2) number of participating contestants and 3) higher points in heavier weight category.

Article 7. Duration of Contest

The duration of the contest shall be three rounds of two minutes each, with a one-minute rest period between rounds.

In case of a tie score after the completion of the 3rd round, a 4th round of two minutes will be conducted as the sudden death overtime round, after a one-minute rest period following the 3rd round.

Article 8. Drawing of Lots

1. The drawing of lots shall be conducted one day prior to the first competition in the presence of the WTF officials and the representatives of the participating nations, and the drawing of lots shall be done from Fin weight up in the English alphabetical order of the official names of the participating nations.
2. Officials shall be designated to draw lost on behalf of the officials of participating nations not present at the drawing.
3. The order of the draw may be changed according to the decision of the Head of Team meeting.

Article 9. Weigh-in

1. Weigh-in of the contestants on the day of competition shall be completed on the previous day of the pertinent competition.
2. During weigh-in, the male contestant shall wear underpants and the female contestant shall wear underpants and brassiere. However, weigh-in may be conducted in the nude in the case that the contestant wishes to do so.
3. Weigh-in shall be made once, however, one more weigh-in is granted within the time limit to the contestant who did not qualify the first time.
4. So as not to be disqualified during official weigh-in, scales, the same as the official one, shall be provided at the contestants' place of accommodation or at the arena for pre-weigh-in.

Article 10. Procedure of the Contest

1. Call for contestants

The name of the contestants shall be announced three times beginning three minutes prior to the scheduled start of the contest. The contestant who fails to appear in the contest area within one minute after the scheduled start of the competition shall be regarded as withdrawn.

2. Physical and Costume Inspection

After being called, the contestants shall undergo physical and costume inspection at the designated inspection desk by the inspector designated by the WTF, and the contestant shall not show any signs of aversion, and also shall not bear any materials which may cause harm to the other contestant.

3. Entering Competition Area

After inspection, the contestant shall enter into the waiting position with one coach.

4. Start and end of the contest

The contest in each round shall begin with the declaration of "Shi-jak (start)" by the referee and shall end with the declaration of "Keu-man (stop)" by the referee. Even if the referee has not declared "Keu-man", the contest shall be regarded as having ended when the prescribed time is over.

5. Procedure before the Beginning and after the End of the Contest

- 1) The contestants shall face each other and make a standing bow at the referee's command of "Cha-ryeot (attention)" and "Kyeong-rye (bow)". A standing bow shall be made from the natural standing posture of "Cha-ryeot" by bending the waist at an angle of more than 30 degrees with the head inclined to an angle more than 45 degrees and the fists clenched at the sides of the legs.
- 2) The referee shall start the contest by commanding "Joon-bi (ready)" and "Shi-jak (start)".
- 3) After the end of the last round, the contestants shall stand at their respective position facing each other and exchange a standing bow at the referee's command of "Cha-ryeot", "Kyeong-rye", and then wait for the referee's declaration of decision in a standing posture.
- 4) The referee shall declare the winner by raising his/her own hand to the winner's side.
- 5) Retirement of the contestants

6. Contest Procedure in Team Competition

- 1) Both teams shall stand facing each other in line in submitted team order towards the 1st Boundary Line from the Contestants' marks.
- 2) Procedure before the beginning and after the end of the contest shall be

conducted as in Item 5 of this article.

- 3) Both teams shall leave the Contest Area and stand by at the designated area for each contestant's match.
- 4) Both teams shall line up in the Contest Area immediately after the end of the final match facing each other.
- 5) The referee shall declare the winning team by raising his/her own hand to the winning team's side

Article 11. Permitted Techniques and Areas

1. Permitted Techniques

- 1) Fist technique: Delivering techniques by using the front parts of the forefinger and middle finger of the tightly clenched fist.
- 2) Foot technique: Delivering techniques by using the parts of the foot below the ankle bone

2. Permitted Areas

- 1) Trunk: Attack by fist and foot techniques on the areas covered by the trunk protector are permitted. However, such attacks shall not be made on the part of the spine.
- 2) Face: This area is the face excluding the back of the head, and attack by foot techniques only is permitted.

Article 12. Valid Points

1. Legal Scoring Areas

- 1) Mid-section of the trunk: The part covered by the trunk protector
- 2) Face: The whole part of the face including both ears

2. Points shall be awarded when permitted techniques are delivered accurately and

powerfully to the legal scoring areas of the body.

3. The valid points are divided as follows.

- 1) One (1) point for attack on trunk protector
- 2) Two (2) points for attack on face.
- 3) One (1) additional point shall be awarded in the event that the contestant is knocked down and the referee counts.

4. Match score shall be the sum of points of the three rounds.

5. Invalidation of points: When a contestant performs an attack to score through the use of the prohibited acts, the points scored shall be annulled.

Article 13. Scoring and Publication

1. Valid points shall be immediately recorded and publicized.

2. In the use of body protectors not equipped with electronics, valid points shall be immediately marked by each judge by using the electronic scoring instrument or judge's scoring sheet.

3. In the use of electronic trunk protectors

- 1) Valid points scored on the mid-section of the trunk shall be recorded automatically by the transmitter in the electronic trunk protector.
- 2) Valid points scored to the face shall be marked by each judge by using the electronic scoring instrument or judge's scoring sheet.

4. In the case of scoring with an electronic scoring instrument or on a judge's scoring sheet, valid points shall be those recognized by at least three or more judges.

Article 14. Prohibited acts and Penalties

1. Penalties on any prohibited acts shall be declared by the referee.

2. Penalties are divided into "Kyong-go (warning penalty)" and "Gam-jeom (deduction penalty)".

3. Two “Kyong-go”s shall be counted as deduction of one (1) point. However, the odd “Kyong-go” shall not be counted in the grand total.

4. A “Gam-jeom” shall be counted as minus one (-1) point.

5. Prohibited acts

1) The following acts shall be classified as prohibited acts, and “Kyong-go” shall be declared.

- a. Crossing the Boundary Line
- b. Evading by turning the back to the opponent
- c. Falling down
- d. Avoiding the match
- e. Grabbing, holding or pushing the opponent
- f. Attacking below the waist
- g. Pretending injury
- h. Butting or attacking with knee
- i. Hitting the opponent’s face with the hand
- j. Uttering undesirable remarks or any misconduct on the part of a contestant or a coach

2) The following acts shall be classified as prohibited acts, and “Gam-jeom” shall be declared.

- a. Attacking the opponent after “Kal-yeo”
- b. Attacking the fallen opponent
- c. Throwing down the opponent by grappling the opponent’s attacking foot in the air with the arm or by pushing the opponent with the hand
- d. Intentionally attacking the opponent’s face with the hand
- e. Interrupting the progress of the match on the part of a contestant or a coach
- f. Violent or extreme remarks or behavior on the part of a contestant or a coach

6. When a contestant intentionally refuses to comply with the Competition Rules or the referee’s order, the referee may declare the contestant loser by penalty after one (1) minute.

7. When a contestant receives minus four (-4) points, the referee shall declare the

contestant loser by penalties.

8. "Kyong-go" and "Gam-jeom" shall be counted in the total score of the three rounds.

9. When the referee suspends a contest for declaration of 'Kyong-go' or 'Gam-jeom', the contest time shall not be counted from the moment of the referee's declaration of 'Kye-shi' until 'Kye-sok' is declared for resumption of the contest.

Article 15. Sudden Death and Decision of Superiority

1. In the event of a tied score after the completion of the 4th round, the winner shall be decided by superiority of all refereeing officials. The final decision shall be based on the initiative shown during the 4th round.

Article 16. Decisions

1. Win by K.O

2. Win by Referee Stop Contest (RSC)

3. Win by score or superiority

(1) Win by final score

(2) Win by Point Gap

When there is a 7-point gap, the match will be stopped and a winner declared.

(3) Win by Point Ceiling

When a competitor scores a maximum of 12 points, the match shall be stopped and a winner declared.

4. Win by withdrawal

5. Win by disqualification

6. Win by referee's punitive declaration

Article 17. Knock Down

1. When any part of the body other than the sole of the foot touches the floor due to the force of the opponent's delivered technique.
2. When a contestant is staggered showing no intention or ability to pursue the match
3. When the referee judges that the contest cannot continue as the result of any power technique having been delivered.

Article 18. Procedure in the event of a Knock Down

1. When a contestant is knocked down as the result of the opponent's legitimate attack, the referee shall take the following measures.
 - 1) The referee shall keep the attacker away from downed contestant by declaration of "Kal-yeo (break)".
 - 2) The referee shall count aloud from "Ha-nah (one)" up to "Yeol (ten)" at one second interval towards the downed contestant, making hand signals indicating the passage of time.
 - 3) In case the downed contestant stands up during the referee's count and desires to continue the fight, the referee shall continue the count up to "Yeo-dul (eight)" for recovery of the downed contestant. The referee shall then determine if the contestant is recovered and, if so, continue the contest by declaration of "Kye-sok (continue)".
 - 4) When a contestant who has been knocked down cannot demonstrate the will to resume the contest by the count of "Yeo-dul (eight)", the referee shall announce the other contestant winner by K.O.
 - 5) The count shall be continued even after the end of the round or the expiration of the match time
 - 6) In case both contestants are knocked down, the referee shall continued counting as long as one of the contestants has not sufficiently recovered.
 - 7) When both contestants fail to recover by the count of "Yeol", the winner shall be decided upon the match score before the occurrence of Knock Down.
 - 8) When it is judged by the referee that a contestant is unable to continue, the referee may decide the winner either without counting or during the counting.

2. Procedures to be followed after the contest

Any contestant suffering a knockout as the result of a blow to the head will not be allowed to compete for the next 30 days. Before entering a new contest after 30 days, the contestant must be examined by a medical doctor designated by the National

Taekwondo Association, who must certify that the contestant is recovered and able to compete.

Article 19. Procedures for suspending the match

When a contestant is to be stopped due to the injury of one or both contestants, the referee shall take the following measures, while in case of the situation which warrants suspending the contest beyond the prescribed procedure, the referee shall declare “Shi-gan (time)” and resume the contest by declaring “Kye-sok (continue)”.

1. The referee shall suspend the contest by declaration of “Kal-yeo” and order the recorders to suspend the time keeping by announcing “Kye-shi (suspend)”.
2. The referee shall allow the contestant to receive first aid within one minute.
3. The contestant who does not demonstrate the will to continue the contest after one minute, even in the case of a slight injury, shall be declared loser by the referee.
4. In case resumption of the contest is impossible after one minute, the contestant causing the injury by a prohibited act to be penalized by “Gam-jeom” shall be declared loser.
5. In case both the contestants are knocked down and are unable to continue the contest after one minute, the winner shall be decided upon points scored before the injuries occurred.
6. When it is judged that a contestant’s health is at risk due to losing consciousness of falling in an apparently dangerous condition, the referee shall suspend the contest immediately and order first aid to be administered. The referee shall declare as loser, the contestant causing the injury if it is deemed to have resulted from a prohibited attack to be penalized by “Gam-jeom”, or in the case the attack was not deemed to be penalized by “Gam-jeom”, shall decide the winner on the basis of the score of the match before suspension of the time.

Article 20. Refereeing Officials

1. Qualifications

Holders of International Referee Certificate registered by the WTF

2. Duties

1) Referee

- (1) The referee shall have control over the match]
- (2) The referee shall declare “Shi-jak”, “Keu-man”, “Kal-yeo”, “Kye-sok” and “Kye-shi”, winner and loser, deduction of points, warnings and retiring. All the referees’ declarations shall be made when the results are confirmed.
- (3) The referee shall have the right to make decisions independently in accordance with the prescribed rules.
- (4) The referee shall not award points.
- (5) In case of a tie or scoreless match the decision of superiority shall be made by all refereeing officials after the end of the fourth round.

2) Judges

- (1) The judges shall mark the valid points immediately.
- (2) The judges shall state their opinions forthrightly when requested by the referee.

3. Responsibility for Judgement

Decisions made by the referees and judges shall be conclusive and they shall be responsible to the Competition Supervisory Board for those decisions.

4. Uniform of the Refereeing Officials

- 1) The referees and judges shall wear the uniform designated by the WTF.
- 2) The refereeing officials shall not carry or take any materials to the arena which might interfere with the contest.

Article 21. Recorder

The recorder shall time the contest and periods of time-out, suspension, and also shall record and publicize the awarded points, and/or deduction of points.

Article 22. Assignment of Refereeing Officials

1. Composition of Refereeing Officials' Squad

- 1) With the use of a non-electronic trunk protector, the officials' squad is composed of one (1) referee and four (4) judges.
- 2) With the use of an electronic trunk protector, the officials' squad is composed of one (1) referee and two (2) judges.

2. Assignment of Refereeing Officials

- 1) The assignment of the referees and judges shall be made after the contest schedule is fixed.
- 2) Referees and judges with the same nationality as that of either contestant shall not be assigned to such a contest. However, an exception shall be made for the judges when the number of refereeing officials is insufficient as the case may be.

Article 23. Other matters not specified in the Rules

In the case that any matters not specified in the Rules occur, they shall be dealt with as follows.

1. Matters related to the competition shall be decided through consensus by the refereeing officials of the pertinent contest.
2. Matters not related to the specific contest shall be decided by the Executive Council or its proxy.
3. The Organizing Committee shall prepare a video tape recorder at each court for recording and preservation of the match process.

Article 24. Arbitration and Sanction

1. Composition of the Competition Supervisory Board

- 1) Qualification of members – Qualified Competition Supervisory Board members shall be members of the WTF Executive Council or persons with sufficient Taekwondo experience and who are recommended by the WTF President or Secretary General. One Technical Delegate shall be the ex-officio member.
- 2) Composition of the Competition Supervisory Board: one Chairman and fewer than six members plus the Technical Delegate
- 3) The President, on the recommendation of the Secretary General, shall appoint the Chairman and members of the Competition Supervisory Board.

2. Responsibility: The Competition Supervisory Board shall make corrections of referees' or judges' misjudgments in accordance to the board members' decisions on protests, and take disciplinary action against officials who make such misjudgments or engage in any illegal behavior. The results of such disciplinary decisions shall be sent to the Secretariat of the WTF. The Competition Supervisory Board shall evaluate the performances of referees and judges. The Competition Supervisory Board shall also concurrently act as the Extraordinary Committee of Sanction during competition with regard to competition management matters.

3. Procedure of Protest

- 1) In case there is an objection to a referee judgement, an official delegate of the team must submit an application for re-evaluation of decision (protest application) together with the prescribed fee to the Competition Supervisory Board within 10 minutes after pertinent contest.
- 2) Deliberation of re-evaluation shall be carried out excluding those members with the same nationality as that of either contestant concerned, and resolution on deliberation shall be made by majority.
- 3) The members of the Competition Supervisory Board may summon the refereeing officials for confirmation of events.
- 4) The resolution made by the Competition Supervisory Board will be final and no further means of appeal will be applied.

4. Procedure of Sanction

- 1) The WTF President or Secretary General (in case of their absence, the Technical Delegate) may request the Extraordinary Committee of Sanction for deliberation when any of the following behaviors are committed by a coach or

a contestant.

- a. Interfering with the management of contest
 - b. Stirring up the spectators or spreading false rumor
- 2) When judged reasonable, the Extraordinary Committee of Sanction shall deliberate over the matter and take disciplinary action immediately. The result of deliberation shall be announced to the public and reported to the WTF Secretariat afterwards.
- 3) The Extraordinary Committee of Sanction may summon the person concerned for confirmation of events.

Enacted : **May 28, 1973**
:

Revised : **Oct. 1, 1977**
:

Revised : **Feb. 23, 1982**
:

Revised : **Oct. 19, 1983**
:

Revised : **June 1, 1986**
:

Revised : **Oct. 7, 1989**
:

Revised : **Oct. 28, 1991**
:

Revised : **Aug. 17, 1993**
:

Revised : **Nov. 18, 1997**
:

Revised : **Oct. 31, 2001**
:

Revised : **Sep. 23, 2003**
:

Revised : **April 12, 2005**

Printed : **2005. 4. 25 (Printed: April 27, 2005)**

Operational status :

1) Article 7, Duration of Contest, and Article 15, Sudden Death and Decision of Superiority, shall be in effect as of April 13, 2005 during the 17th (10th Women's) World Taekwondo Championships.

2) Following Articles shall take effect during the first officially promoted WTF event of World Cup Taekwondo Team Championships 2006 to be held on May 4-9, 2006.

Article 3.1 Competition Area

Article 3.2 Competition Area

Article 4.2 Contestant

Article 13.4 Scoring and Publication

Article 16.3 Decisions

Article 22.1 Assignment of Refereeing Officials

Article 24.1 Arbitration and Sanction